



Russian Supercomputing Days 2019

Multiscale supercomputer simulation of gas purification processes

*Sergey Polyakov, Yuri Karamzin, Tatiana Kydryashova,
Viktoriya Podryga, Dmitry Puzyrkov, Nikita Tarasov*

Keldysh Institute of Applied Mathematics

Russian Academy of Sciences

Moscow, Russia

ECOLOGY PROBLEMS

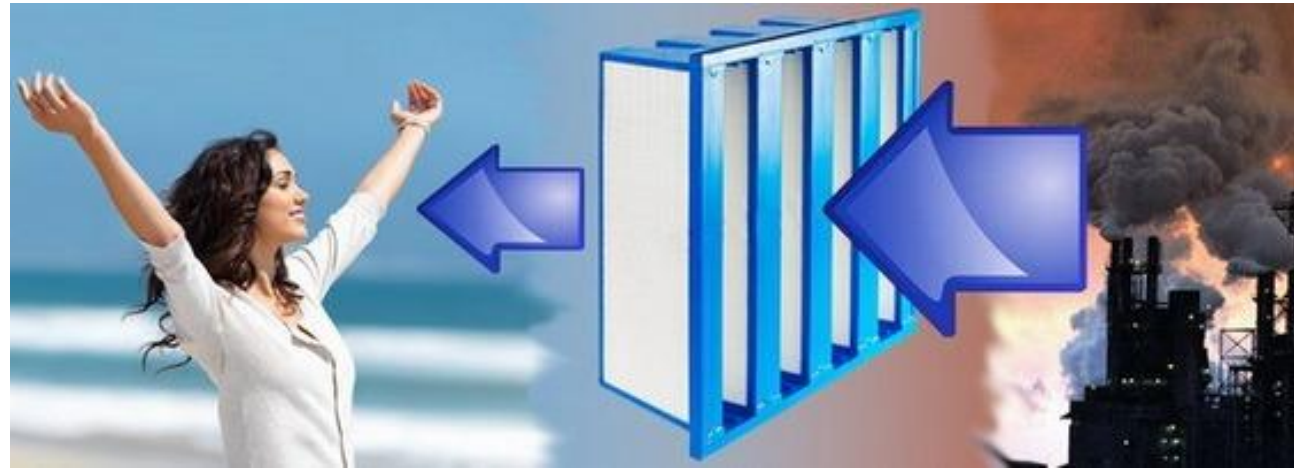

- Indoor air may be polluted with various impurities. Poor quality of building components, a large number of electronic equipment and poor-quality cleaning contribute to this. A lot of dust accumulates on the bookshelves...
- High humidity in the room creates the conditions for harmful bacteria and mold. Polluted air reduces the human performance, affects health
- Nanotechnology products enter the environment without studying the effects of this process

Air purification is an important condition to create the balance of air at home and work areas.

APPLICATIONS

- the electronics industry to create clean industrial rooms;
- precision engineering and aerospace industry;
- healthcare to create sterile environment;
- the microbiological and pharmaceutical industry to produce drugs and products;
- the chemical industry to obtain a dust-free atmosphere in film and photo production;
- the nuclear industry for air purification from radioactive aerosols;
- the food industry in food production plants.
- homes, hotels, offices where clean air is especially needed to ensure human health.

PHYSICAL METHODS

Mechanical ways for dust, mist, oils, gaseous impurities

Filters :

- Mechanical.
- Electrostatic.
- Carbon.
- Photocatalytic.
- Water.

Physico-chemical ways

Sorption

- adsorption
- absorption

Catalytic (neutralization of impurities with a catalyst)

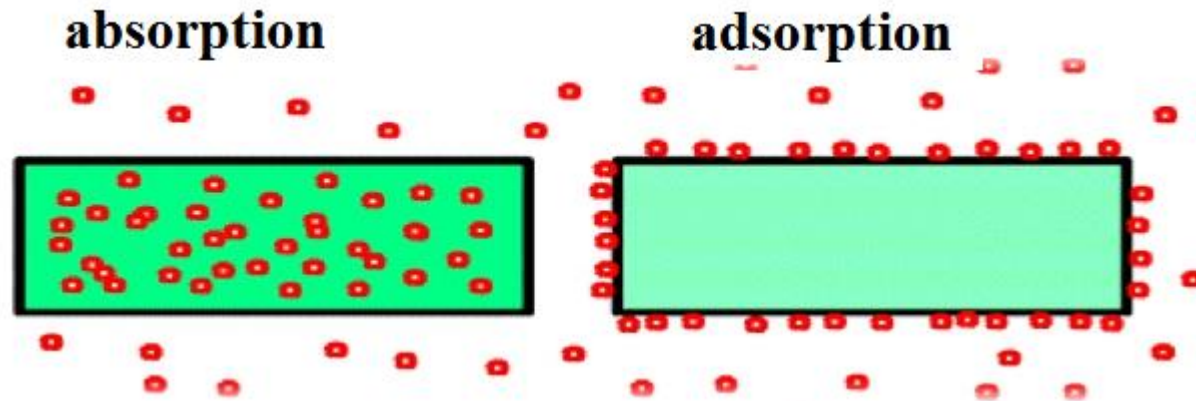

Dry, unpolluted air has the following chemical composition:

SORBENTS

nitrogen - 78.08%, oxygen - 20.95%, inert gases - 0.94%, carbon dioxide - 0.03%.

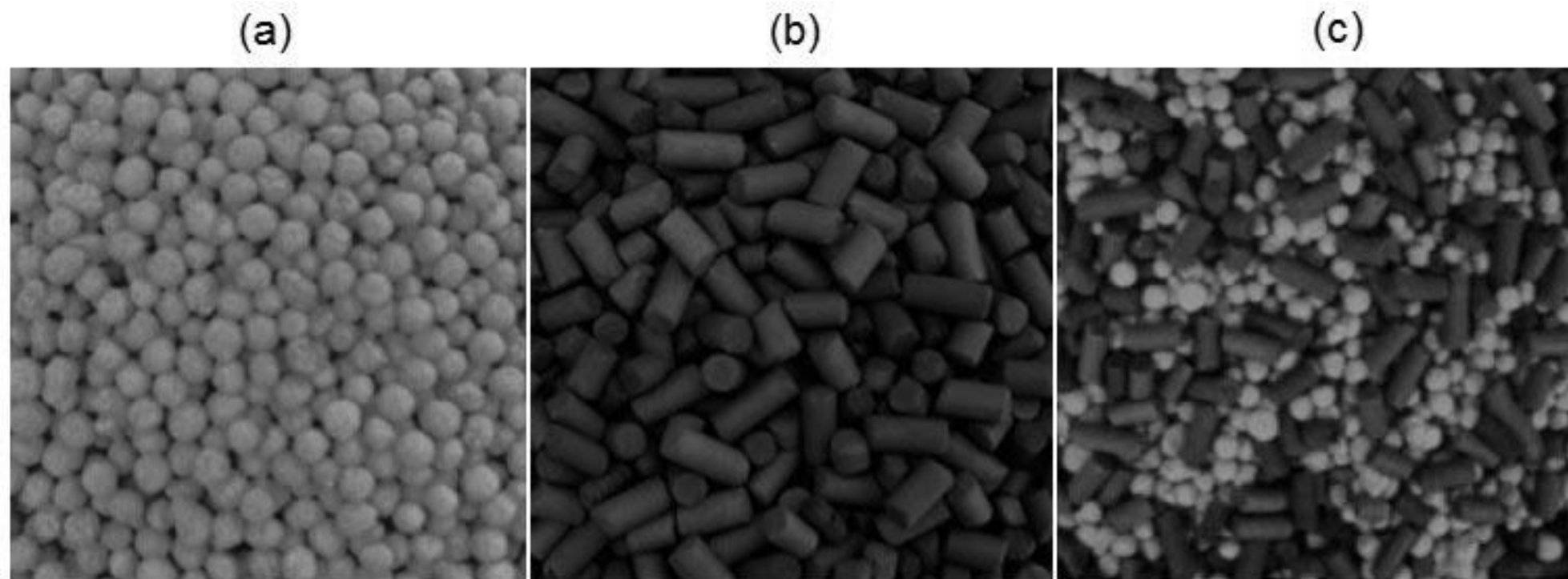

SORPTION AIR PURIFIER

In - Polluted air inlet;

Out - Purified air outlet;

1 - Sorption chamber.

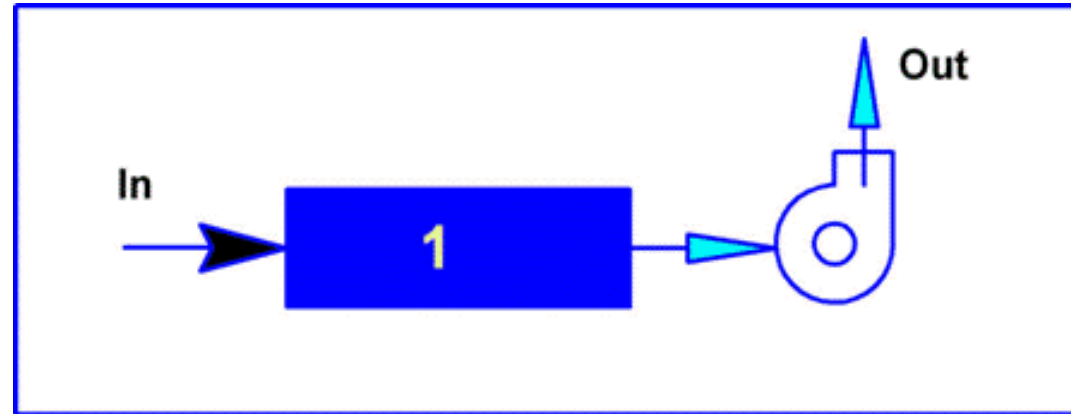

The sorption technology is based on the ability of certain substances (sorbents) to capture harmful gases or particles from air. The cleaning unit is a container with a sorbent. Polluted air is passed through this container. After saturation of the sorbent, it is burned, or is to be buried, or undergoes regeneration.

MAT

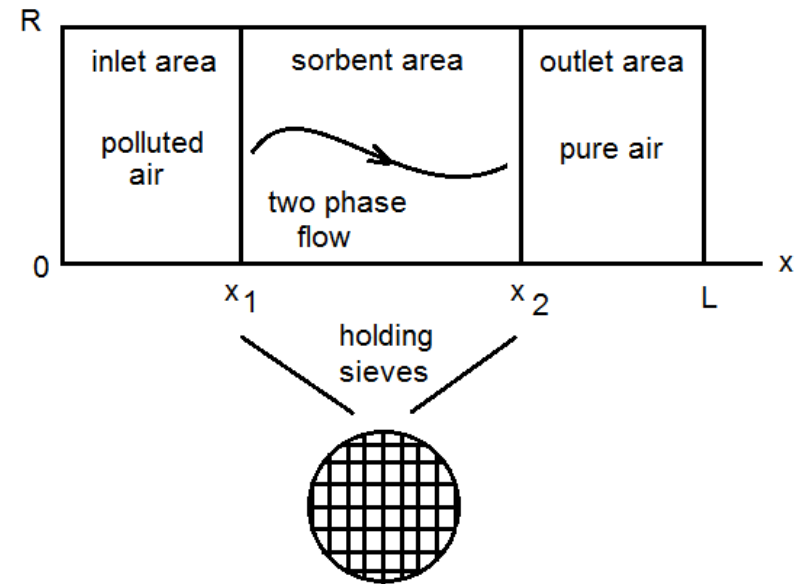
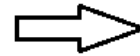
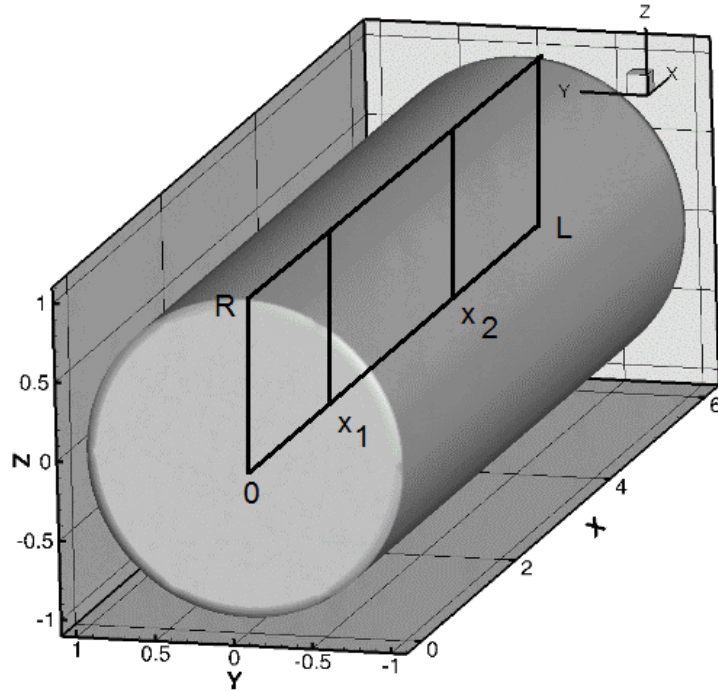

Calculations were carried out for 2D (x-y) and 3D(x-y-z) geometry

Macro level: the sizes of the technical system (TS) are lengths of structural elements

Micro level: the sizes of the near surface layers of the channels and structural units are close to atomic (~20-100 nm) $10^3 - 10^9$

The multiscale approach is based on the use of two models describing physical processes at the macro and micro levels.

Newton's system of equations (MD) is used as a micromodel

As a macro model, the system of equations of hydrodynamics (GD) is applied

MACRO MODEL: QUASI GAS DYNAMIC (QGD) EQUATION SYSTEM FOR GAS MIXTURE

T.G. Elizarova, Quasi-gasdynamics equations. *Springer*, 286 p.p., 2009

$$\frac{\partial \rho_l}{\partial t} + \operatorname{div} \mathbf{W}_l^{(\rho)} = 0, \quad \mathbf{W}_l^{(\rho)} = \rho_l \mathbf{u}_l - \rho_l \mathbf{w}_l, \quad \mathbf{w}_l = \tau \left[(\mathbf{u}_l, \nabla) \mathbf{u}_l + \frac{1}{\rho_l} \nabla p_l \right],$$

$$\frac{\partial}{\partial t} \rho_l u_{l,k} + \operatorname{div} \mathbf{W}_l^{(\rho u_k)} = S_l^{(\rho u_k)},$$

$$\mathbf{W}_l^{(\rho u_k)} = \rho_l \mathbf{u}_l u_{l,k} + \mathbf{e}_k \left(p_l + \frac{2}{3} \mu_l \operatorname{div} \mathbf{u}_l \right) - \mu_l (\nabla u_{l,k} + (\nabla, \mathbf{e}_k) \mathbf{u}_l) - (\rho_l \mathbf{w}_{l,k} \mathbf{u}_l + \rho_l \mathbf{w}_l u_{l,k}),$$

$$S_l^{(\rho u_k)} = \nu_{ll'} \rho_l (\bar{u}_{l',k} - u_{l,k}), \quad l = a, b, \quad l' = b, a, \quad k = 1, 2, 3,$$

$$\frac{\partial}{\partial t} E_l + \operatorname{div} \mathbf{W}_l^{(E)} = S_l^{(E)},$$

$$\mathbf{W}_l^{(E)} = (\rho_l \mathbf{u}_l - \rho_l \mathbf{w}_l) H_l - \chi_l \nabla T_l + \left(\frac{2}{3} \mu \operatorname{div} \mathbf{u}_l \right) \mathbf{u}_l - \sum_{k=1,2,3} \mu (\nabla u_{l,k} + (\nabla, \mathbf{e}_k) \mathbf{u}_l) + (\rho_l \mathbf{w}_l, \mathbf{u}_l) \mathbf{u}_l,$$

$$S_l^{(E)} = \nu_{ll'} \rho_l (\bar{E}_{l'} - E_l), \quad l = a, b, \quad l' = b, a, \quad E_l = \frac{1}{2} \rho_l |\mathbf{u}_l|^2 + \rho_l \varepsilon_l, \quad p_l = Z_l \rho_l \mathfrak{R}_l T_l, \quad \varepsilon_l = c_{v,l} T_l$$

MICROMODEL: MOLECULAR DYNAMICS

Newton's system of equations

$$\begin{cases} m_l \frac{d\mathbf{v}_{l,i}}{dt} = \mathbf{F}_{l,i}, \\ \frac{d\mathbf{r}_{l,i}}{dt} = \mathbf{v}_{l,i}, \end{cases}$$

i - particle number,

l - particle type,

N_l - total particle l type

l,i - particle l type with i number

$m_{l,i}$ - particle mass

$$\mathbf{F}_{l,i} = -\frac{\partial U(\mathbf{r}_{l,1}, \dots, \mathbf{r}_{l,N})}{\partial \mathbf{r}_{l,i}} + \mathbf{F}_{l,i}^{ext},$$

$$i = 1, \dots, N_l, \quad l = 1, \dots, N_{tot} \quad (N_{tot} \equiv N_{gas} + N_{met}),$$

$$\mathbf{r}_{l,i} = (r_{x,l,i}, r_{y,l,i}, r_{z,l,i}) \quad - \text{radius vector}$$

$$\mathbf{v}_{l,i} = (v_{x,l,i}, v_{y,l,i}, v_{z,l,i}) \quad - \text{speed vector}$$

$$\mathbf{F}_{l,i} = (F_{x,l,i}, F_{y,l,i}, F_{z,l,i}) \quad - \text{total force acting on this particle}$$

INITIAL CONDITIONS

Temperature $T(K)$	273.15
Pressure $p (Pa)$	101325
Density $\rho(kg / m^3)$	1.25
Viscosity $\mu(kg / (m \cdot s))$	$1.7894 \cdot 10^{-5}$
Input flow velocity $u_x (m / s)$	0.143152
Computational domain (m^2)	0.04 x 0.02

The initial conditions correspond to the equilibrium gas environment in the absence of interaction with external factors

The initial conditions at the microlevel are determined by the equilibrium or quasiequilibrium thermodynamic state of the particle system at a given temperature, pressure, and average momentum.

BOUNDARY CONDITIONS

The Poiseuille flow is set at the entrance to the system, the so-called “soft” boundary conditions are set at the exit from the system

$$\frac{\partial \rho_l}{\partial n} = 0, \quad \frac{\partial (\rho_l \mathbf{u}_l)}{\partial n} = 0, \quad \frac{\partial p_l}{\partial n} = 0, \quad l = a, b.$$

On solid walls of the channel, conditions of sliding are specified..

$$u_x = 0, \quad \frac{\partial u_y}{\partial x} = 0, \quad \frac{\partial p}{\partial y} = 0, \quad \frac{\partial T}{\partial y} = 0$$

On the surface of the granules,

$$u_x = 0, \quad \frac{\partial u_y}{\partial x} = 0, \quad \frac{\partial p}{\partial y} = 0, \quad \frac{\partial T}{\partial y} = 0$$

These conditions describe the process of absorption of a part of the energy and momentum of a gas by the surface of a granules.

$$\begin{aligned} (\mathbf{W}_l^{(\rho)}, \mathbf{n}) &= -\alpha_l (\rho_l - \rho_l^{(w)}), \quad (\mathbf{W}_l^{(\rho u_k)}, \mathbf{n}) = -\beta_{l,k} (\rho_l u_{l,k} - \rho_{l,w} u_{l,k}^{(w)}), \quad k = x, y, z, \quad (\mathbf{W}_k^{(C)}, \mathbf{n}) = -A_k (C_k - C_k^*) (C_k^{**} - C_k). \\ (\mathbf{W}_l^{(E)}, \mathbf{n}) &= -\eta_l (E_l - E_l^{(w)}), \quad l = a, b. \end{aligned}$$

1. Consistently: **CONNECTING MACRO AND MICRO MODELS**

We analyze the adhesion process of nanoparticles to the surface of the sorbent granule or absorption of nanoparticles by sorbent granule (MD method). Based on such a calculation, the parameters boundary conditions on the surface of the granule are formed. Then they are used in macro model (QGD equations).

2. Parallel :

In this case, parameters of boundary conditions on each granule are calculated by MD method before the next step of QGD modeling.

NUMERICAL ALGORITHM FOR MACRO LEVEL

The system of QGD equations is solved on the basis of the explicit time grid numerical algorithm.

For 2D case, quadrangular and triangular cells were used. In 3D case, parallelepipeds, tetrahedrons and prisms with a triangular base were used as cells.

Rough meshes in the 2D case and triangular meshes on the surface of the granules were constructed using an original algorithm based on the Delone criterion. Tetrahedral meshes were built in the ANSYS CFX package.

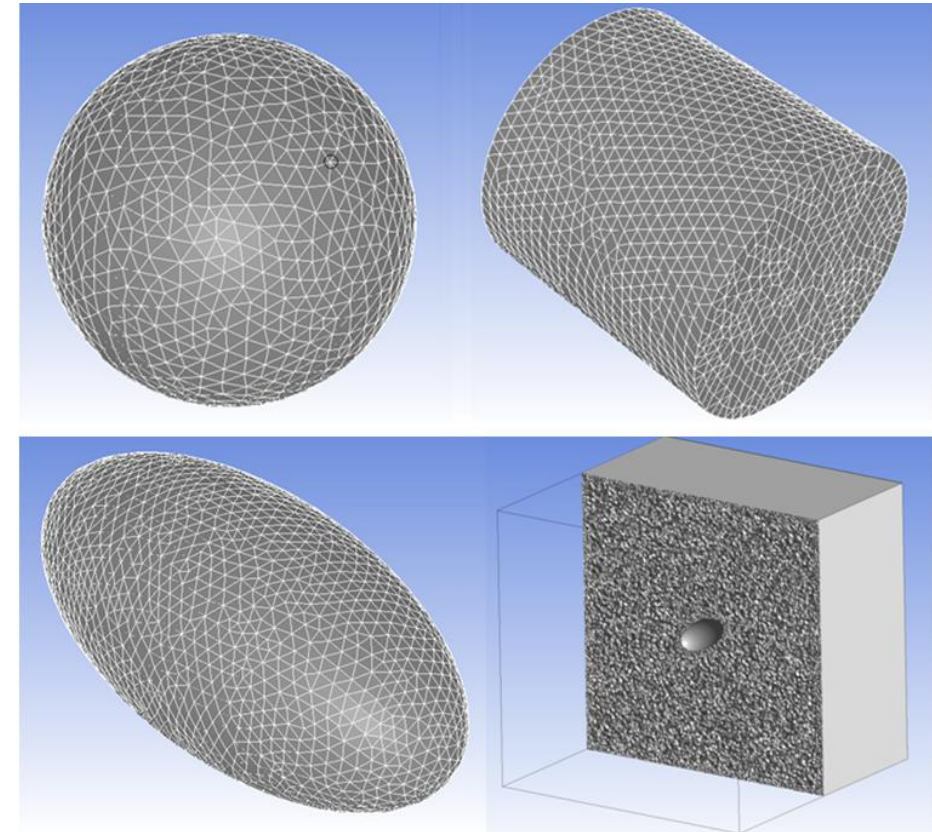

NUMERICAL ALGORITHM FOR MICRO LEVEL

$$\mathbf{F}_{l,i}^0 = \mathbf{F}_{l,i} \left(\mathbf{r}_{1,1}^0, \dots, \mathbf{r}_{1,N_1}^0; \dots; \mathbf{r}_{N_{tot},1}^0, \dots, \mathbf{r}_{N_{tot},N_{N_{tot}}}^0 \right), \quad i = 1, \dots, N_l, \quad l = 1, \dots, N_{tot};$$

$\mathbf{F}_{l,i}^n$ - the value of the force on the n step

$$\forall n = 0, 1, 2, \dots: \quad \mathbf{r}_{l,i}^{n+1} = \mathbf{r}_{l,i}^n + \mathbf{v}_{l,i}^n \Delta t + \frac{\mathbf{F}_{l,i}^n (\Delta t)^2}{2m_l}, \quad i = 1, \dots, N_l, \quad l = 1, \dots, N_{tot};$$

$\mathbf{F}_{l,i}$ - the procedure for calculating the forces

$$\mathbf{F}_{l,i}^{n+1} = \mathbf{F}_{l,i} \left(\mathbf{r}_{1,1}^{n+1}, \dots, \mathbf{r}_{1,N_1}^{n+1}; \dots; \mathbf{r}_{N_{tot},1}^{n+1}, \dots, \mathbf{r}_{N_{tot},N_{N_{tot}}}^{n+1} \right), \quad i = 1, \dots, N_l, \quad l = 1, \dots, N_{tot};$$

$$\mathbf{v}_{l,i}^{n+1} = \mathbf{v}_{l,i}^n + \frac{\mathbf{F}_{l,i}^{n+1} + \mathbf{F}_{l,i}^n}{2m_l} \Delta t, \quad i = 1, \dots, N_l, \quad l = 1, \dots, N_{tot}.$$

To achieve a given temperature by the microsystem, the Berendsen thermostat is used.

To achieve a given temperature and momentum, the Langevin thermostat is used.

Circles (with a radius of 0.001 m and number is 40) and ovals of elliptical shape were considered as granules (with the main axes of 0.002 m and 0.001 m and number is 21).

Both configurations were chosen as follows:

- the granules fill the channel completely,
- the sorbent layer was about the same thickness,
- the areas occupied by the granules approximately coincided

$$S_{sphere} = 1.2566 \text{ cm}^2 \quad S_{Ellipse} = 1.3195 \text{ cm}^2$$

Software: Intel C++/Fortran, MPI Library, OpenMP Library, CUDA Toolkit

Parallel technologies: MPI + OpenMP or MPI + OpenMP + CUDA

The domain decomposition technique for different architecture levels :
DOMAIN DECOMPOSITION
nodes of the system, shared memory of cores, thread parallelization

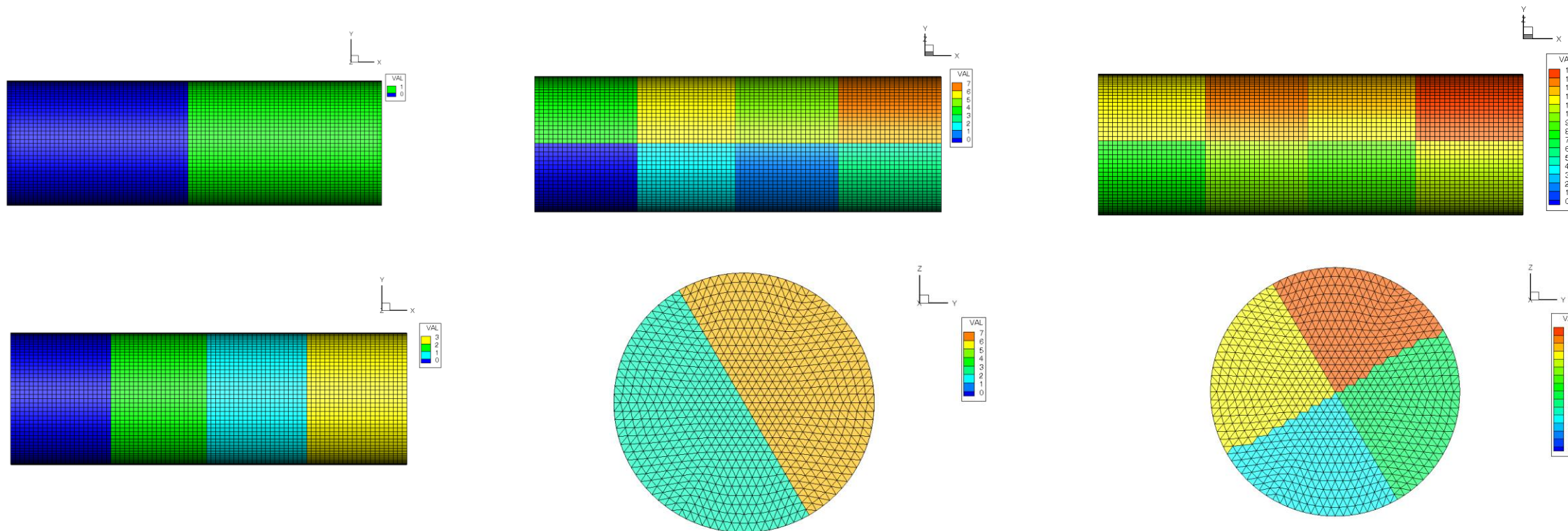

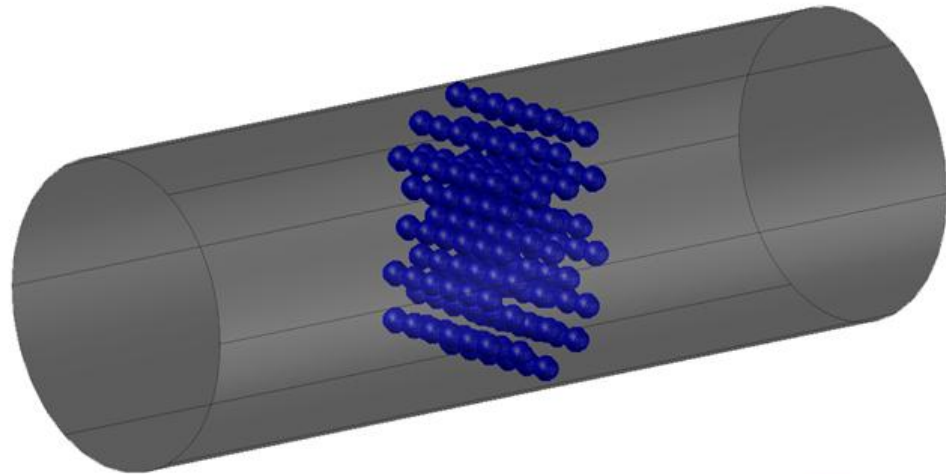

LOAD BALANCING

3D computational domain

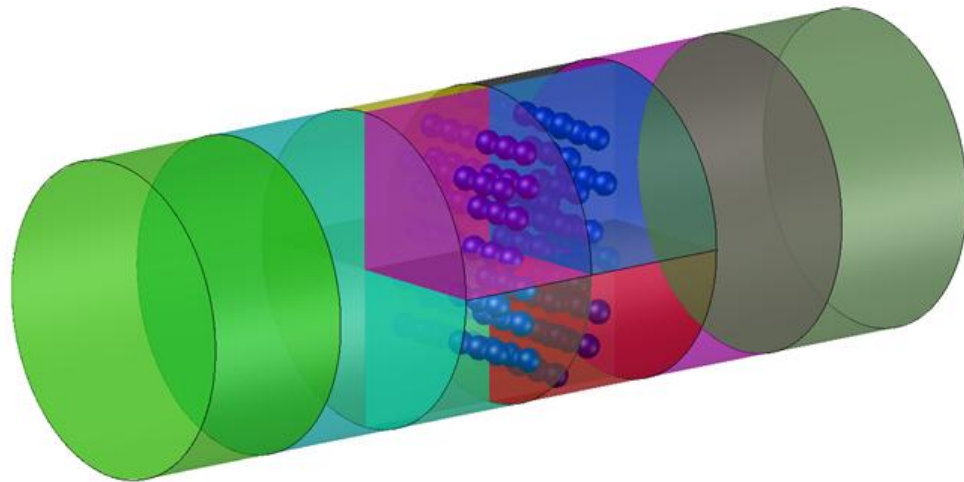

domain decomposition:
pipe decomposition – for inlet and outlet areas,
2d decomposition – for sorbent area

System	Node number	Interconnect type	Processor type	Performance, TFLOPS	Processors per node	Threads per node	RAM per node, GB
K60-CPU	78	InfiniBand FDR, 56 Gbit/s	Intel Xeon E5-2690 v4, 2.6 GHz	74,2	2	28	256
K60-GPU	8	InfiniBand FDR, 56 Gbit/s	NVidia Tesla V100-PCIe, 1.75 GHz	240	4	5120	128
K48-VPU	16	OmniPath, 100 Gbit/s	Intel Xeon Phi KNL 7250F, 1.4 GHz	48	1	272	112

SC/ Processor number	1 ^{*)}	2	4	8	16	32	Acceleration with the maximum number of calculators	Efficiency with the maximum number of calculators, %
K60-CPU	26.407	14.274	7.633	4.438	2.756	1.914	13.797	43.115
K60-GPU	8.832	5.076	2.751	1.670	1.316	0.972	9.144	28.576
K48-VPU	68.964	35.733	18.612	10.134	5.442	2.964	23.267	72.710

*) to achieve the minimum time of the task solution on the calculator, the optimal number of parallel flows (blocks) was selected.

- for processors on the K60-CPU, the optimal number of parallel threads was 28,
- for processors on K48-VPU - 64.
- on the K60-GPU, the linear memory structure with the number of blocks 160 and the number of parallel threads in the block 512.

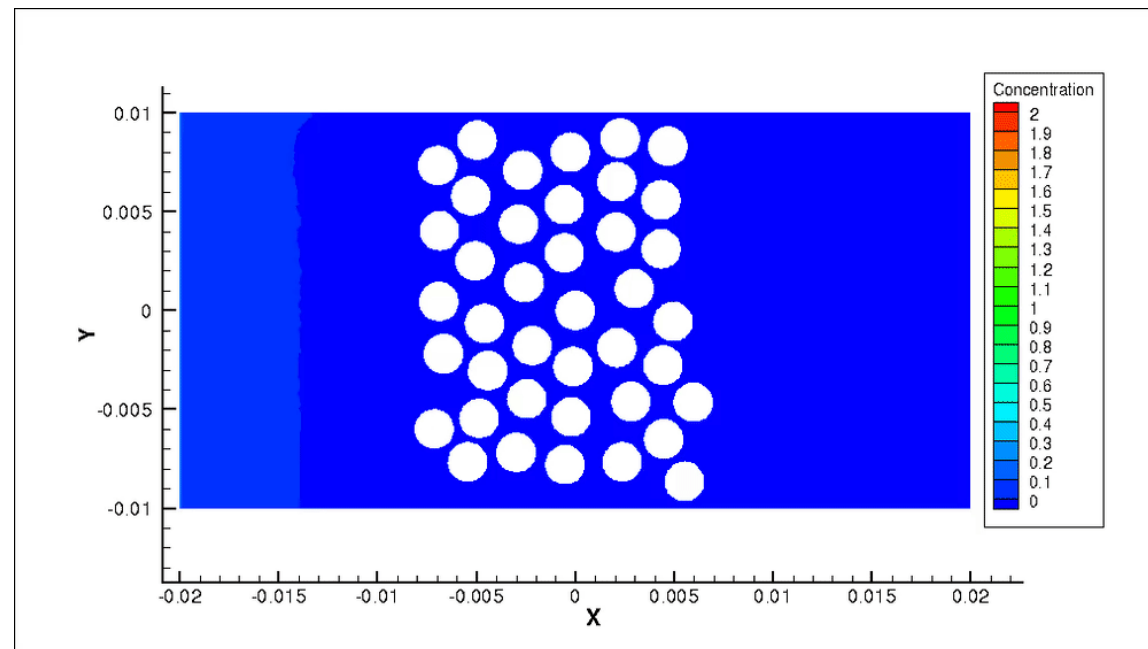
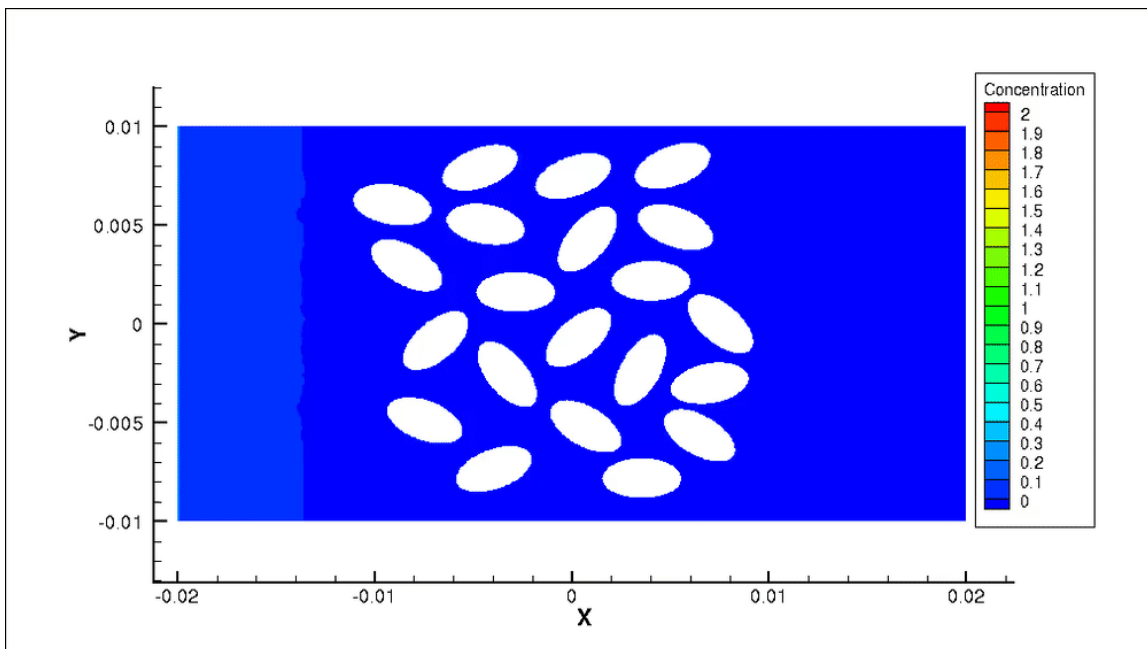

Concentration of pollutant

3D RESULTS SOLUTION CONCENTRATION

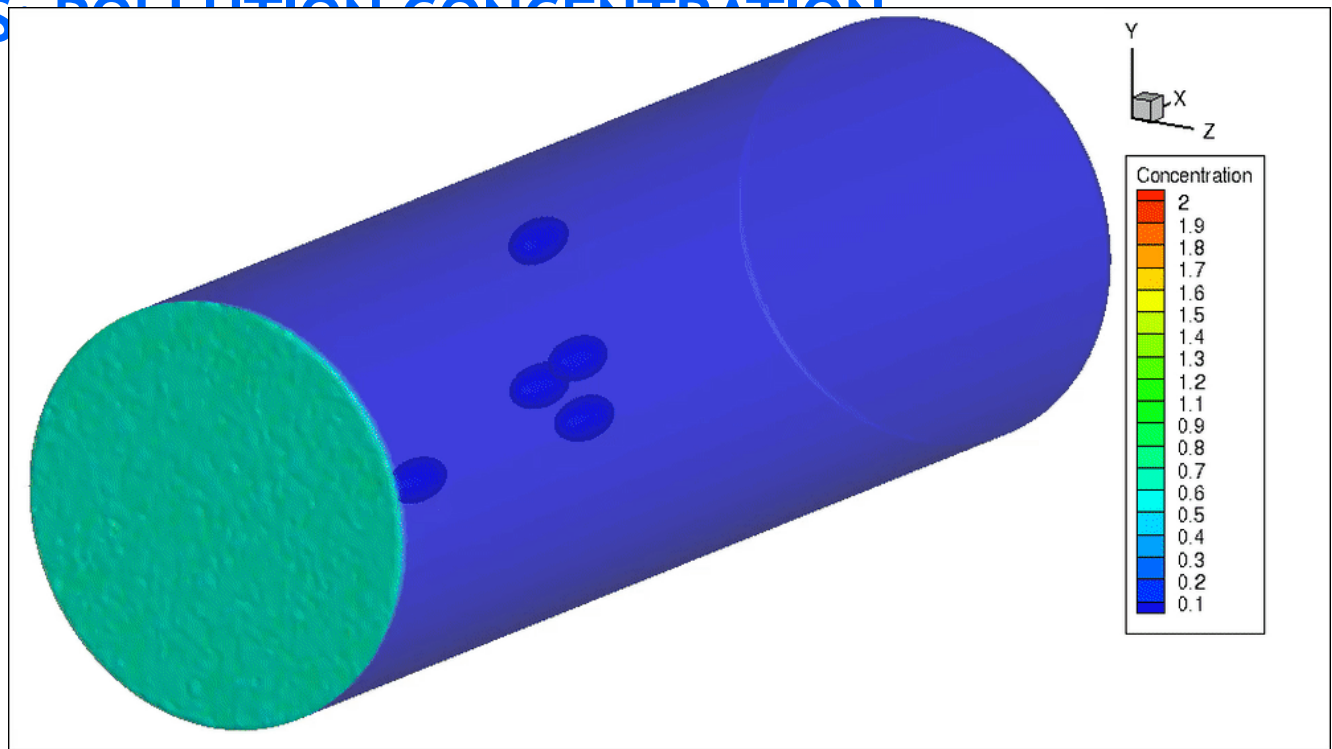

CONCLUSION

- The supercomputer modeling technology for air purification processes are presented in the paper
- The simulated cleaning method is based on the use of granular sorbents. Mathematical model, numerical algorithm and its parallel implementation were developed
- Originality of this approach is the use of QGD method with multiscale approach.
- Test calculations confirmed the performance of the developed supercomputer technology.

THANKS FOR THE ATTENTION!